



ALUMINIUM LOADCELLS

LOADCELL 601-130mm

SINGLE POINT BENDING BEAM LOAD CELL



Specifications:

Model No.	601 130mm Regular
Brand:	Green Label CZL-601, D Local
Rated Load:	3/6/10/20/40/80 kg
Applications:	Bench, Counting & Postal Scales, Check Weighers(Recommended platform size : 250x350mm)
Material:	Aluminium
Pcs. Per Box:	100 pcs

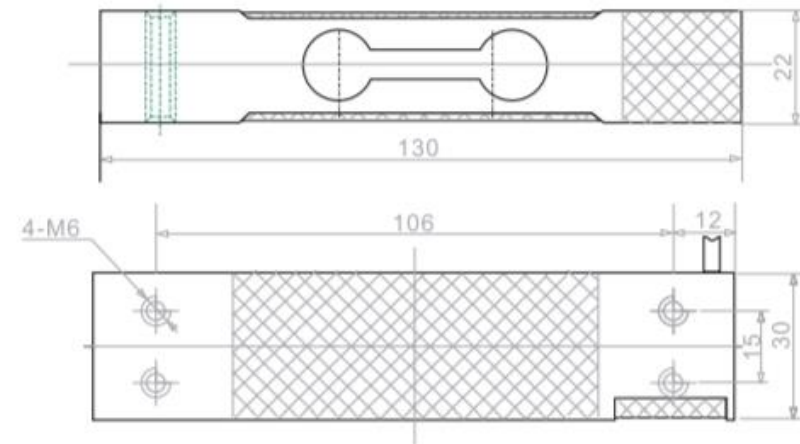

LOADCELL 601- 88mm



SINGLE POINT BENDING BEAM LOAD CELL



Specifications:

Model No.	601 (GATTU) (CHOTU)
Rated Load:	20/40/80 kg
Applications:	Bench, Counting & Postal Scales, Check Weighers(Recommended platform size : 250x250mm)
Material:	Aluminium
Pcs. Per Box:	200 pcs

LOADCELL 601 AC (3 Hole)

PARELLEL BEAM ALUMINIUM LOAD CELL



Model No.	601 AC (3 Hole)
Brand:	Green Label CZL-601 AC, D local
Rated Load:	150/200 kg
Pcs. Per Box:	60 pcs
Cable:	4mm

Applications

- Bench, Counting & Postal Scales.
- Check Weighers. (Recommended platform size up to 400x400mm)

Features:

- Accurate Precision and least temperate effect
- Single Point Off-centre Load Measuring Capability.
- Economical and Low Profile Cell.
- Aluminum-alloy, Colorless anodized
- Glue sealed with IP67

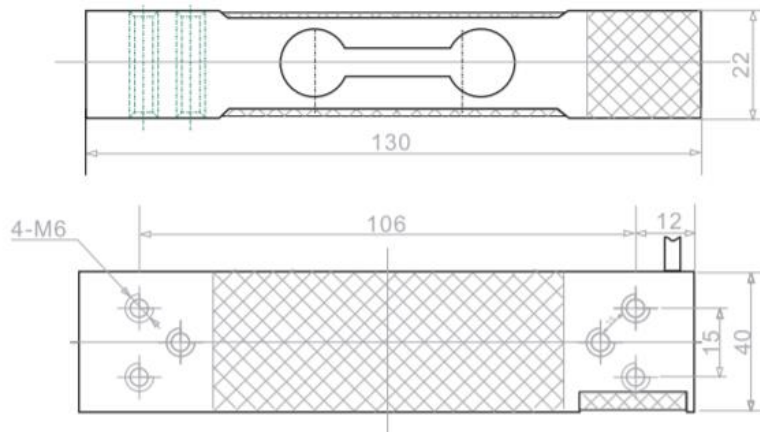



LOADCELL 642 (25X25) 30mm

SINGLE POINT ALUMINIUM LOAD CELL

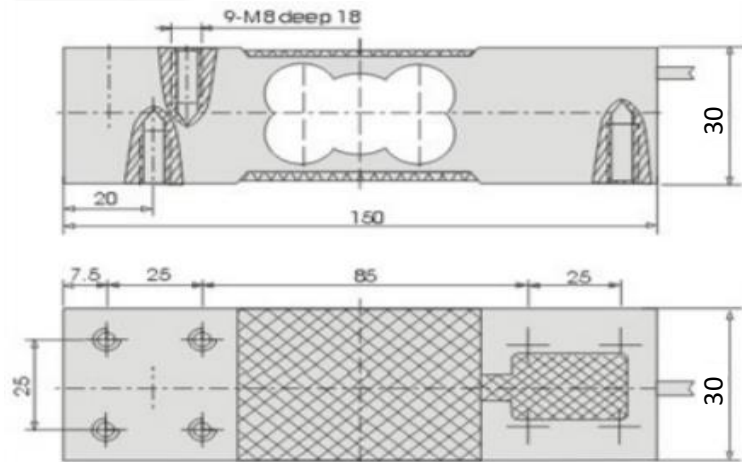
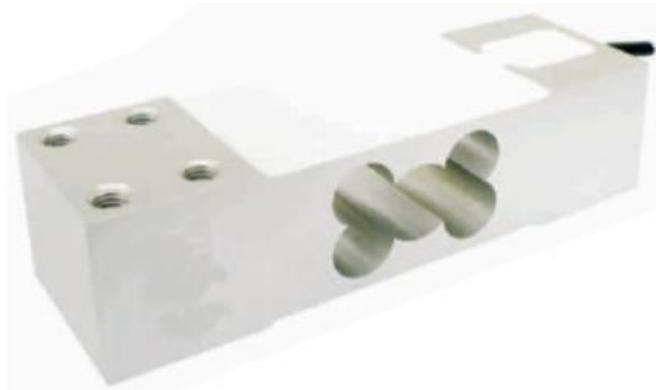

Model No.	642 (25X25) (4 Hole)
Size:	30mm
Brand:	Green Label CZL-642, D Local
Rated Load:	100/200/300/500 kg
Pcs. Per Box:	30 pcs
Cable:	4mm, 3 meters

Features:

- Economical and low profile cell
- Aluminum-alloy; Colourless anodized
- Hermetically sealed with glue to IP65

Applications

- Platform Scales
- Bench, Counting & Postal Scales.
- Check Weighers. (Recommended platform size up to 500x500mm)
- Industrial Weighing Systems



LOADCELL 642 (25X25) 35mm

SINGLE POINT ALUMINIUM LOAD CELL

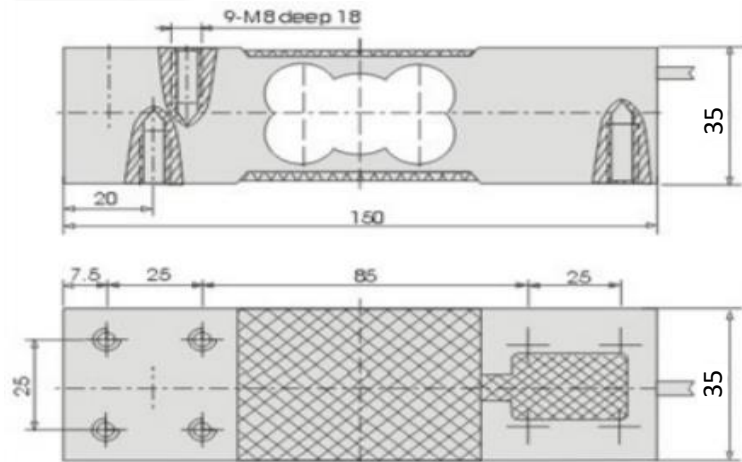

Model No.	642 (25X25) (4 Hole)
Size:	35mm
Brand:	Green Label CZL-642, D Local
Rated Load:	100/200/300/500 kg
Pcs. Per Box:	30 pcs
Cable:	4mm, 3 meters

Features:

- Economical and low profile cell
- Aluminum-alloy; Colourless anodized
- Hermetically sealed with glue to IP65

Applications

- Platform Scales
- Bench, Counting & Postal Scales.
- Check Weighers. (Recommended platform size up to 500x500mm)
- Industrial Weighing Systems



LOADCELL 642 (25X25) 40mm

SINGLE POINT ALUMINIUM LOAD CELL

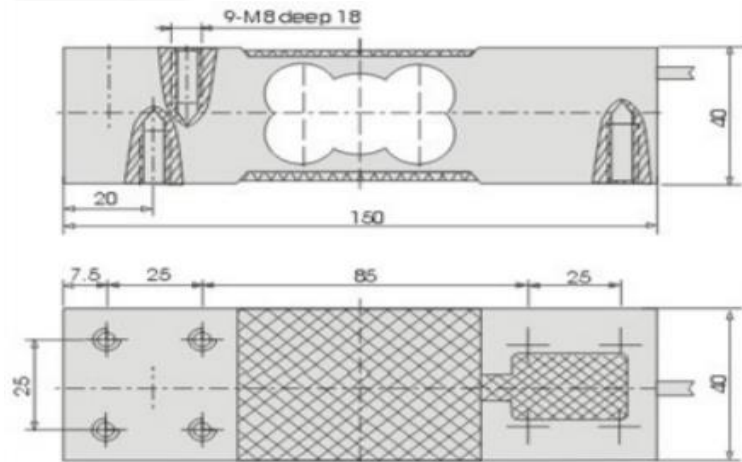
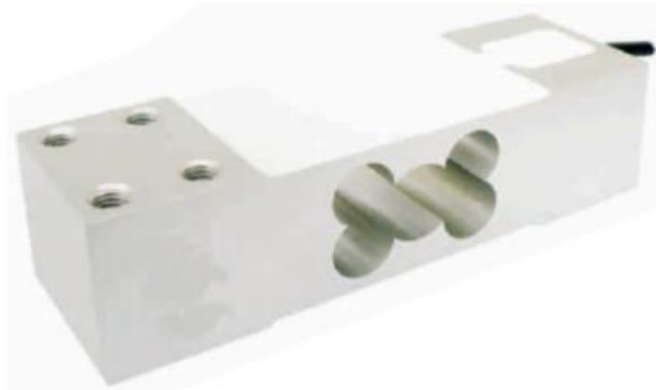

Model No.	642 (25X25) (4 Hole)
Size:	40mm
Brand:	Green Label CZL-642, D Local
Rated Load:	100/200/300/500 kg
Pcs. Per Box:	30 pcs
Cable:	4mm, 3 meters

Features:

- Economical and low profile cell
- Aluminum-alloy; Colourless anodized
- Hermetically sealed with glue to IP65

Applications

- Platform Scales
- Bench, Counting & Postal Scales.
- Check Weighers. (Recommended platform size up to 500x500mm)
- Industrial Weighing Systems

LOADCELL 646B (25X35)

SINGLE POINT ALUMINIUM LOAD CELL

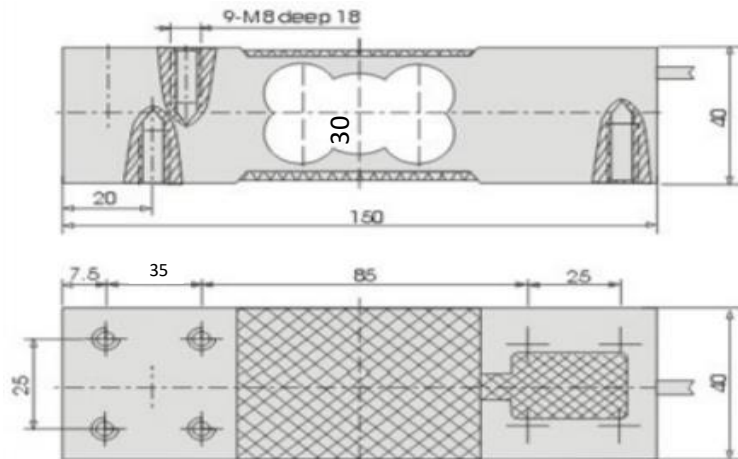

Model No.	646B (25X35) (4 Hole)
Brand:	CZL 646B, D Local
Rated Load:	300/500/750/1000 kg
Pcs. Per Box:	20 pcs
Cable:	4mm, 3 meters

Features:

- High rated Loadcell with 4 hole 25X35 size.
- Economical and Low Profile Cell.
- Aluminum-alloy
- Glue sealed with long wire

Applications

- Bench, Counting & Postal Scales.
- Platform Scales
- Check Weighers . (Recommended platform size up to 600x600mm)

LOADCELL (JEWELLERY)

MINIATURE LOAD CELL



Model No. LAK-B, Jewellery loadcell
Brand: LCT, Zemic (USA), Green Label
Rated Load: 0.3kg, ..., 3 Kg
Protection Class: IP65

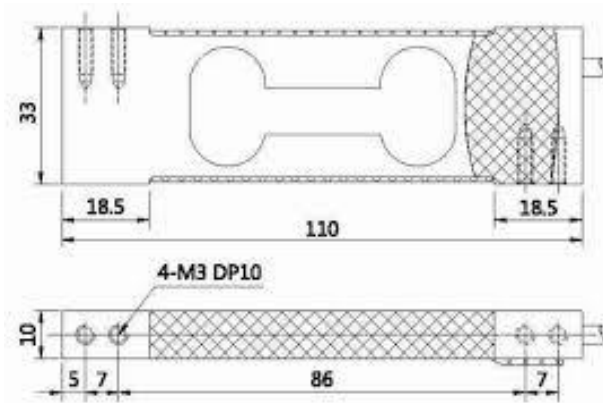

Applications

- Electronic balance
- Counting scales
- Weighing scales
- Retail scales
- Jewellery scale



STEEL LOADCELLS

S.S. CUT SIZE LOADCELL (25x25)

SINGLE POINT PLAT FORM LOAD CELL

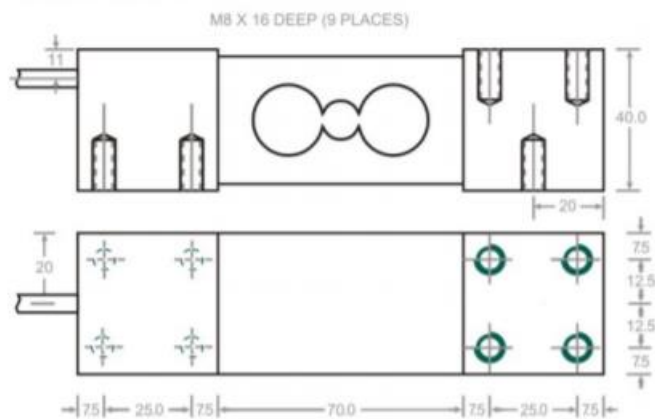
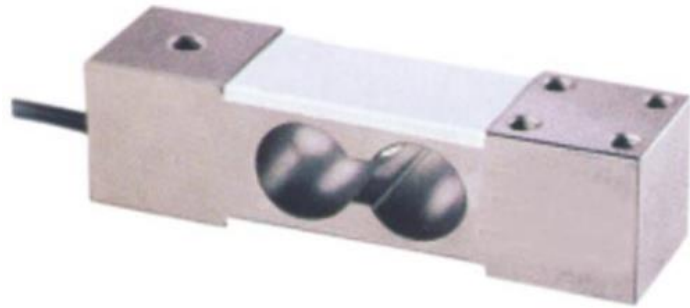

Model No.	310 (25x25)
Brand:	Rudraa Sensor, Delux
Rated Load:	100/200/300/500 kg
Pcs. Per Box:	10/12 pcs
Cable:	6mm, 2.5 meters
Defend Grade:	IP67
Warranty:	1 Year

Features:

- Single Point Capability for Platform Scale
- Minimum error for Off-Centre loading
- Supports the Platform size up to 600 x 600 (mm)
- Low profile
- Compact, Light Weight & Economical

Applications

- Smaller Size Economical Platform Scales
- Bag Weighers
- Hopper Weighers

S.S. REGULAR LOADCELL (25x35)

SINGLE POINT BENDING BEAM LOAD CELL

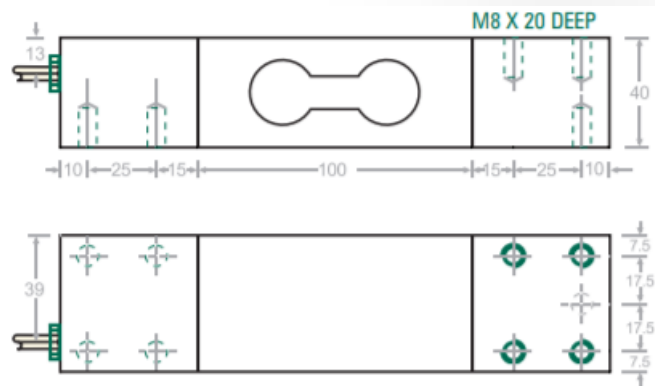

Model No.	410 (25x35)
Brand:	Rudraa Sensor, Delux
Rated Load:	100/200/300/500/750/1000 kg
Pcs. Per Box:	12/10 pcs
Cable:	6mm, 2.5 meters
Warranty:	1 Year

Features:

- Single Point Capability for Platform Scale
- Minimum error for Off-Centre loading
- Supports the Pan size up to 750 x 750 (mm)
- Low profile
- SS, Suitable for hygienic applications like, Food, Dairy & Pharmaceutical Industries

Applications

- Medium Size Platform Scales
- Bag Weighers
- Hopper Weighers

S.S. JUMBO LOADCELL (25x50)

SINGLE POINT HEAVY PLATFORM LOAD CELL

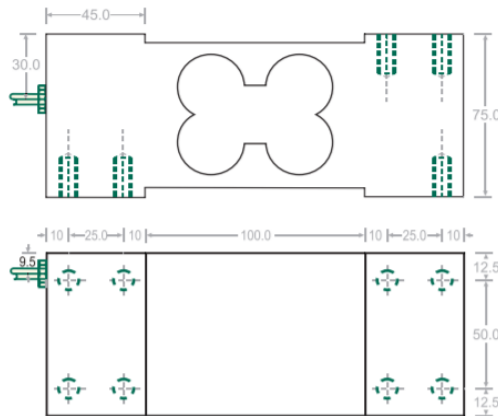
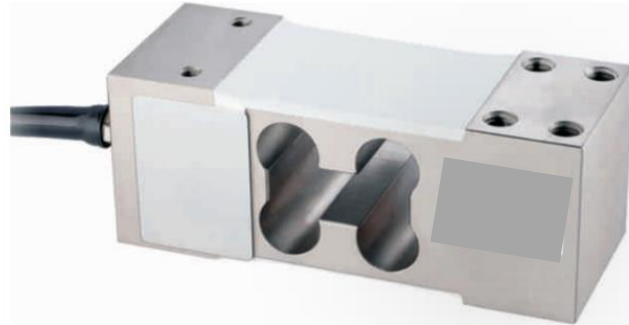

Model No.	410 (25x35)
Brand:	Rudraa Sensor, Delux
Rated Load:	1Ton / 1.5Ton / 2Ton / 3Ton
Pcs. Per Box:	5 pcs
Cable:	6mm, 4 meters
Warranty:	1 Year
IP Grade:	IP67

Features:

- Single Point Capability for Platform Scale
- Minimum error for Off-Centre loading
- Support platform scale with size 900 x 900 (mm)
- Compact, Light Weight & Economical

Applications

- Large Platform Scales
- Steel Weighers



S-TYPE LOADCELLS

S.S. CUT SIZE LOADCELL (25x25)



SINGLE POINT PLAT FORM LOAD CELL

Model No.	310 (25x25)
Brand:	Rudraa Sensor, Delux
Rated Load:	100/200/300/500 kg
Pcs. Per Box:	10/12 pcs
Cable:	6mm, 2.5 meters
Defend Grade:	IP67
Warranty:	1 Year

Features:

- Single Point Capability for Platform Scale
- Minimum error for Off-Centre loading
- Supports the Platform size up to 600 x 600 (mm)
- Low profile
- Compact, Light Weight & Economical

Applications

- Smaller Size Economical Platform Scales
- Bag Weighers
- Hopper Weighers



SESB LOADCELLS

SINGLE ENDED SHEAR BEAM



SESB-500/1000/2000 KG

SINGLE ENDED SHEAR BEAM LOAD CELL



Model No.

SESB Steel loadcell

Brand:

Kevin Sensors, Zemic, Rudraa Sensor, Delux, Green Label CZL

Rated Load:

500 kg / 1Ton / 2Ton

Pcs. Per Box:

4 pcs

Cable:

6mm, 4 meters /5mm, 5 meter variable

Warranty:

1 Year

IP Grade:

IP67/68

Features:

- Alloy steel construction and hermetically sealed by welding to IP67 & IP68
- Full range of capacities
- Simple construction

Applications

- Electronic Platform Scales
- Ground Weighter
- Hopper Weighing
- Vehicle scale
- Railroad scales
- Tank weighing

SESB- 3 Ton/ 5 Ton

SINGLE ENDED SHEAR BEAM LOAD CELL



Model No.	SESB Steel loadcell
Brand:	Kevin Sensors, Zemic, Rudraa Sensor, Delux, Green Label CZL
Rated Load:	500 kg / 1Ton / 2Ton
Pcs. Per Box:	4 pcs
Cable:	6mm, 4 meters /5mm, 5 meter variable
Warranty:	1 Year
IP Grade:	IP67/68

Features:

- Alloy steel construction and hermetically sealed by welding to IP67 & IP68
- Full range of capacities
- Simple construction

Applications

- Electronic Platform Scales
- Ground Weighter
- Hopper Weighing
- Vehicle scale
- Railroad scales
- Tank weighing